

CUBE MOULD STANDARD: EN 12390-1, BS1881

Test procedures require that specimens are cast in a number of standard sizes convenient for compressive and flexural strength determination. The engineering tolerances specified for moulds are very stringent and the internal finish of the surface must be of a high order to comply with the recommendations laid down in many International standards. Moulds must not deform during manufacture of concrete specimens if the specimen dimensions are to be maintained.



CM-FA ▲

4-part with clamp attached base plate. Cube mould for concrete hardened testing. Material is cast iron. Machined surface finished by flat grinding machine. No distortion during specimen preparation.

Model	Dimension(mm)	Weight(kg)
CM-FA100	100×100×100	9.5
CM-FA150	150×150×150	18

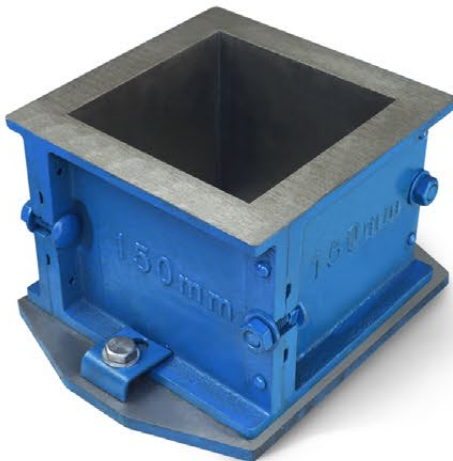

CM-FB CAST IRON CUBE MOULD ▲

4-part with clamp attached base plate.

Model	Dimension(mm)	Weight(kg)
CM-FB100	100×100×100	9
CM-FB150	150×150×150	16

CM-FC CAST IRON CUBE MOULD

Build up by four parts 45 degree wall, save time to assemble or reassemble, we may regard two connect wall as one wall, only want to disjoin two parts together.

Model	Dimension(mm)	Weight(kg)
CM-FC100	100×100×100	9
CM-FC150	150×150×150	16



CM-E CAST IRON CUBE MOULD

Model	Dimension(mm)	Weight(kg)
CM-E100	100×100×100	5.5
CM-E150	150×150×150	10
CM-E200	200×200×200	16



CM-T CAST IRON CUBE MOULD

It is a new design product, one blot connect two parts in every side. Save time to assemble or disassemble the mould. Base clamps on this mould are slotted.

Model	Dimension(mm)	Weight(kg)
CM-T100	100×100×100	9
CM-T150	150×150×150	16



CM-FD150 CAST IRON CUBE MOULD

Manufactured in accordance with dimensions and tolerances stated in EN 12390-1. Four part with base plate. The moulds are designed to be durable, corrosion resistant and easy to clean

Model	Dimension(mm)	Weight(kg)
CM-FD150	150×150×150	13



CM-FS150 STEEL CUBE MOULD

Model	Dimension(mm)	Weight(kg)
CM-FS150	150×150×150	8.8



CM-SA150 STEEL CUBE MOULD

Model	Dimension(mm)	Weight(kg)
CM-SA150	150×150×150	15.8



CM-P PLASTIC CUBE MOULD

It is the best economic mould in this range, it is made of ABS plastic and use special self motion injection plastic machine to squeezed out, one time finished and easy to carry.



Model	Dimension(mm)	Weight(kg)
CM-P100	100×100×100	0.7
CM-P150	150×150×150	0.9
CM-PT150	150×150×150	1.0



CM-PA150 PLASTIC CUBE MOULD

It is reusable and sturdy in this range, it is light and easy to carry, made in collapsible-two parts for quick to install. It will not rust and easy to maintain.

Model	Dimension(mm)	Weight(kg)
CM-PA150	150×150×150	2.7



CM-CU150 POLYURETHANE CUBE MOULD

A one piece mould manufactured from a robust plastic which is resistant to shock and abrasion. Ideal for field use, the specimen is ejected from the mould by compressed air requiring only a simple clean and oiling before being ready for use again. Meets the requirements of EN 12390-1.

Model	Dimension(mm)	Weight(kg)
CM-CU150	150×150×150	1.6



CYLINDER MOULD

STANDARD: ASTM C39, C192 –AASHTO T23, T126

CY-MC CAST IRON CYLINDER MOULD

This type cylinder mould is made of cast iron and surface is coated black or blue and the inner surface is all grinded by the lathe. It's very heavy

Model	Dimension(mm) Dia.×Height	Weight(kg)
CY-MC100	100×200	9
CY-MC150	150×300	17
CY-MC160	160×320	22



CY-CW STEEL CYLINDER MOULD

Model	Dimension(mm) Dia.×Height	Weight(kg)	Wall thickness (mm)
CY-CW100	100×200	9	5



CY-MS STEEL CYLINDER MOULD

These moulds are constructed of plated steel for rust resistance and are dimensionally stable under severe use. Moulds are split along one side with 2 quick-acting clamps welded to mould. When open, mould springs apart slightly to allow specimen removal. Include detachable base plate.

Model	Dimension(mm) Dia.×Height	Weight(kg)
CY-MS50	50×100	1
CY-MS100	100×200	9
CY-MS150	150×300	16
CY-MS160	160×320	18



CY-MP PLASTIC CYLINDER MOULD

Plastic concrete test cylinder mould is reusable and sturdy in this range, it is light and easy to carry, made in collapsible-two parts for quick to install. It will not rust and easy to maintain.

Model	Dimension(mm) Dia.×Height	Weight(kg)
CY-MP/A (with bolt)	100×200	0.89
CY-MP/B (with clip)	100×200	0.92
CY-MP/C (with bolt)	150×300	1.76



CM-PU150 POLYURETHANE CYLINDER MOULD

Model	Dimension(mm) Dia.×Height	Weight(kg)
CM-PU150	150×300	1.9



CM-PU150

CY-PP PLASTIC CYLINDER MOULD

The air gun is generally used for demoulding. Below is the using photo.

Model	Dimension(mm) Dia.×Height	Weight(kg)
CY-PP100	100×200	0.7
CY-PP150	150×300	1



AG150 air gun and CY-PP150 plastic cylinder mould

SPECIMEN CLAMPING TOOL

For transporting of specimen cubes and cylinders.

ST-J150 ▼

Tryout size: 150x150 mm
Weight:0.85kg



ST-L150 ►

Tryout size: 150x300 mm
Weight:1.67kg

BEAM MOULD

STANDARD: EN 12390-1, -2

These beam moulds are designed to produce accurate specimens while avoiding distortion over the length of the mould. The top brim is special design and avoids defacing the machined surface. Inner surface are all machined by grind machine.

CM-GS STEEL THREE GANG MOULD

Model	Dimension(mm)	Weight(kg)
CM-GS40	40×40×40	2.5
CM-GS50	50×50×50	3.5
CM-GS70	70.7×70.7×70.7	7

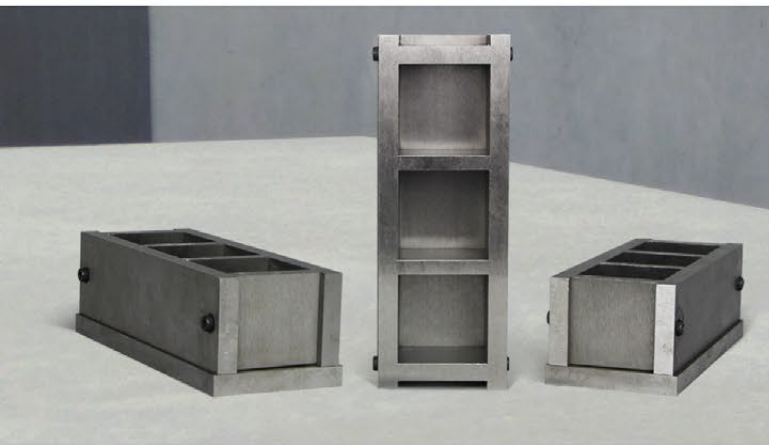

BM-S STEEL BEAM MOULD

Model	Dimension(mm)	Weight(kg)
BM-S13	100×100×300	10
BM-S14	100×100×400	13
BM-S15	100×100×500	15
BM-S55	150×150×500	25
BM-S56	150×150×600	34
BM-S75	150×150×750	44

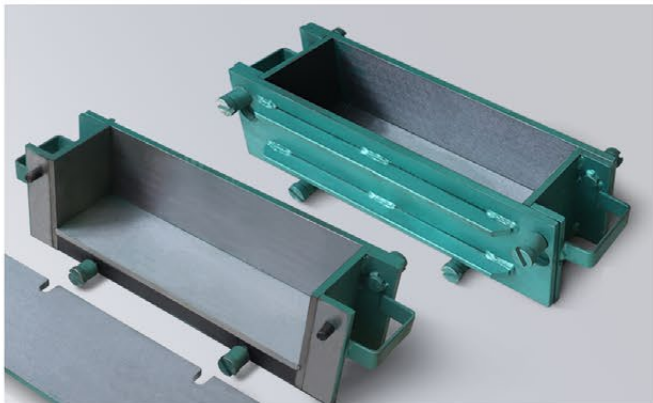

CM-GP SERIES THREE GANG MOULD

These moulds are made of cast iron, steel or ABS plastic. Machined surface finished by flat grinding machine. No distortion during specimen preparation.

Model	Dimension(mm)	Weight(kg)
CM-GP70	70.7×70.7×70.7	0.9
CM-GP100	100×100×100	1.3



CM-GC CAST IRON THREE GANG MOULD

Model	Dimension(mm)	Weight(kg)
CM-GC50	50×50×50	4
CM-GC70	70.7×70.7×70.7	7.5
CM-GC100	100×100×100	12.5
CM-GC150	150×150×150	32



BM-P PLASTIC BEAM MOULD

Model	Dimension(mm)	Remark
BM-P13	100×100×300	ABS plastic
BM-P14	100×100×400	ABS plastic
BM-P53	150×150×300	ABS plastic
BM-P55	150×150×550	ABS plastic



BRIQUETTE MOULD

STANDARD: ASTM C307

For casting of cement briquettes for tensile strength tests. It is a two part split mould made of brass. Two thumb screws facilitate easy and quick assembling and dismantling of the mould. The minimum cross section of the briquettes cast is 25.4 mm x 25.4 mm.

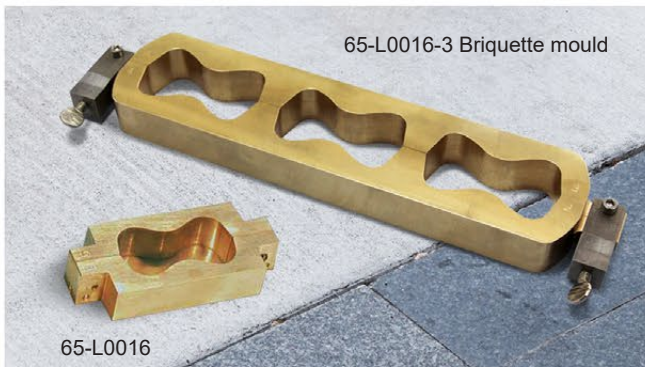

BRASS THREE GANG CUBE MOULD

STANDARD: ASTM C87, AASHTO T71

Machined out of High lead naval brass, this three gang 2" x 2" cube mould makes 3 compression test cubes at a time. This mould casts cubes in a diagonal arrangement with a detachable brass base plate.

Wing nut clamps lock the mould to the base while stainless thumbscrews secure halves tightly together. Large screed off upper surface area makes this mold a preferred choice. Optional accessories include an all brass fitted top, or a cover plate designed to pour molten sulfur capping compound down through taper holes for testing compressive strength.

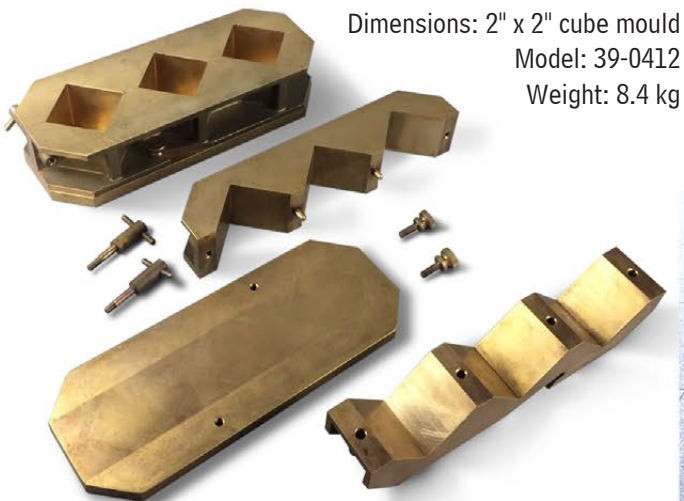

CAST IRON THREE GANG CUBE MOULD

Model: 39-0410

Dimensions: 50 x 50 mm cube mould

Weight: 6.5 kg



TWO/THREE GANG PRISM MOULD

STANDARD: ASTM C490/490M

Model: BM-S25

Dimensions: 25x25x285mm. Gauge length 250mm, total length 285mm.

Made of steel with a maximum surface hardness of HV200.

Weight 6kg approx.



Model: SM-S25

Dimensions: 25x25x285mm

Weight: 6.4 kg approx.





TINPENG

CEMENT TEST MOULD

THREE GANG PRISM MOULD

STANDARD: BS 3892-1, 4551-1, EN 196-1, 413-2, 459-2, 1744-1, 1015-10,11, ISO 679 EN 13454-2.

SM-S41A/B/C are made of steel. The mould is used for casting specimens of cement aggregate combinations for measuring the potential expansive alkali reactivity.

SM-C41 Three gang mould for prisms 40 x 40 x 160mm is made of steel, base plate is made of cast iron.

Model	Dimension(mm)	Weight(kg)
SM-S41A	40 × 40 × 160	9.2
SM-S41B	40 × 40 × 160	12
SM-S41C	40 × 40 × 160	10
SM-C41	40 × 40 × 160	6.5

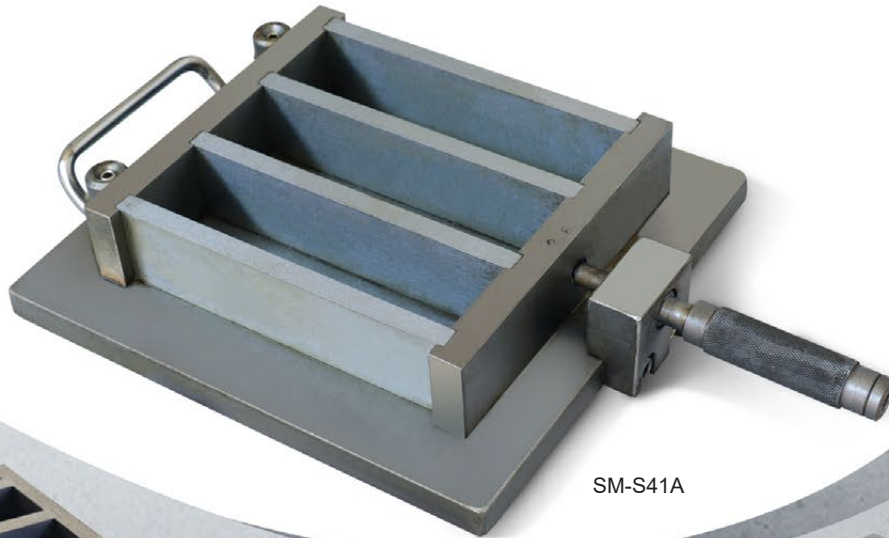

SM-S41A

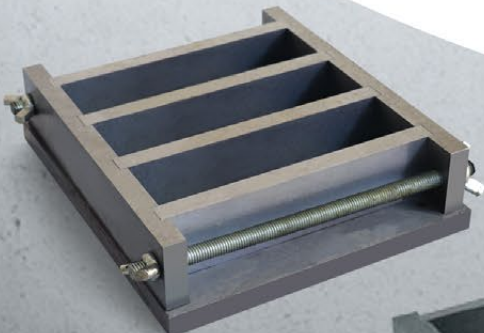

SM-S41C

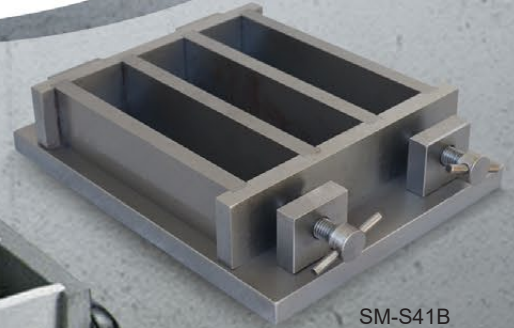

SM-S41B



SM-C41



SINCE 2006

ZHUOZHOU TIANPENG INSTRUMENT MANUFACTURING CO., LTD.
Website: www.testmould.com Tel:+86-312-3852880