

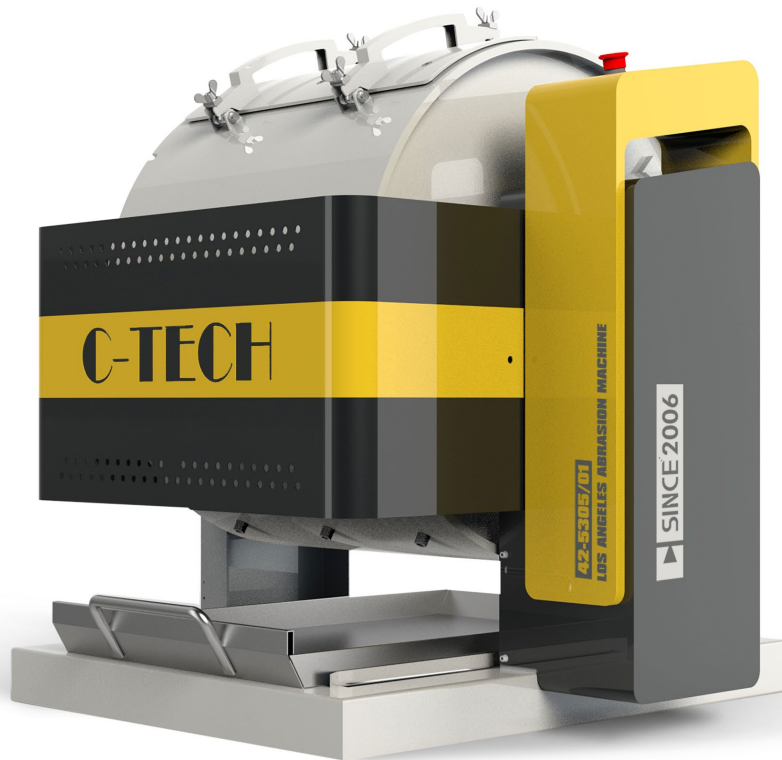

Laboratory equipment co.,limited

LOS ANGELES ABRASION MACHINE EL42-5305/01

PRODUCT MANUAL



C-TECH LABORATORY EQUIPMENT CO., LTD

📍 Building C28, Hegu Technology Industrial Park, Development Zone,
Zhuozhou, Hebei, China

☎ +86-312-3868016/3852880

📠 +86-312-3868882

🌐 www.testmould.com

SINCE 2006

CONTENTS

I. Overview	1
II. Technical specifications	1
III. Packing & Assembly	1
IV. Drawing	2
V. Operation	3



C-TECH LABORATORY EQUIPMENT CO., LTD

 Building C28, Hegu Technology Industrial Park, Development Zone,
Zhuozhou, Hebei, China

 +86-312-3868016/3852880

 +86-312-3868882

I. Overview

Los Angeles abrasion machine consists of a rolled steel drum with a wall thickness of 12mm, an inside diameter of 710 mm and internal length 510 mm. The drum is rotated by a speed reducer driven by an electric motor at a speed of between 31 and 33 r.p.m. The machine is equipped with an automatic counter, which can be preset to the required number of revolutions of the drum. The surface of the machine is powder sprayed.

II. Technical specifications

Internal dimension	φ710mm*510(±5mm)
Rotate speed	30-33 r.p.m
Abrasive charges weight	Set of 12 abrasive charges: 1.13/16" (7 pcs) and 1.7/8" (5 pcs). (ASTM, C.N.R) Option: Set of 12 abrasive charges: 1.7/8" (EN)
Power	AC220V 50HZ/60HZ 0.75KW
Dimension	942*959*948mm
Weight	340kg

III. Packing & Assembly

Each unit is shipped complete with a set of 12 charges and a steel tray. Generally the tray and the carton containing the charges is wire strapped to the lower cross members of this machine.

Electrical Motor and Speed Reducer

Examine the motor carefully to make sure that it has not been damaged during shipment. Be sure that the line voltage and frequency correspond to those stamped on the nameplate. For connections, see diagram attached to the machine.

The ratio-motor gear housing is shipped with oil. Check the oil level and if necessary, be sure to lubricate in accordance with the instructions on the motor plate and included in this manual.

Pillow Blocks

The bearings in all Gear Pillow Blocks are pre-greased at the factory. When relubrication is necessary



C-TECH LABORATORY EQUIPMENT CO., LTD

 Building C28, Hegu Technology Industrial Park, Development Zone, Zhuozhou, Hebei, China

 +86-312-3868016/3852880

 +86-312-3868882

use recommended ball bearing grease of medium consistency and apply by means of an ordinary grease gun and the convenient grease fitting provided.

DO NOT USE OIL FOR RE-LUBRICATION. Additions of grease every three or four months is suggested unless experience proves otherwise. For normal usage, grease having a temperature operating range from 0°F to 150°F is recommended.

IV. Drawing

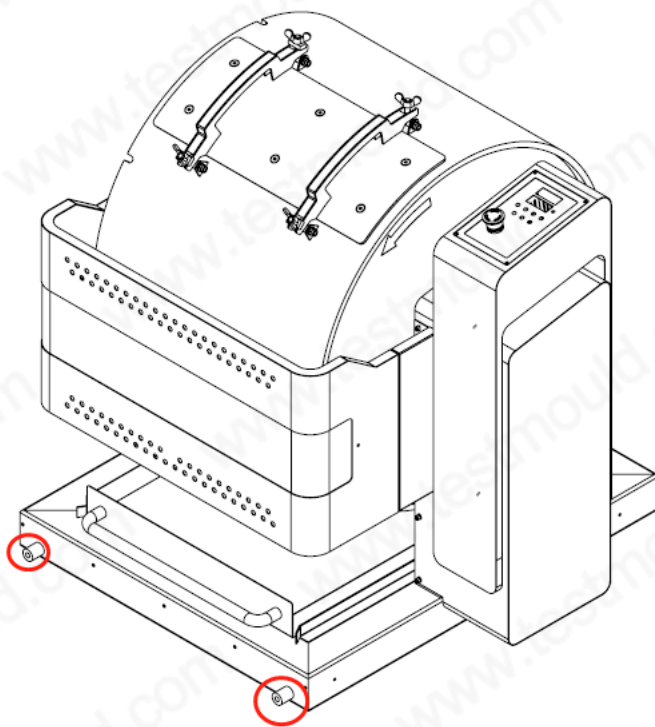
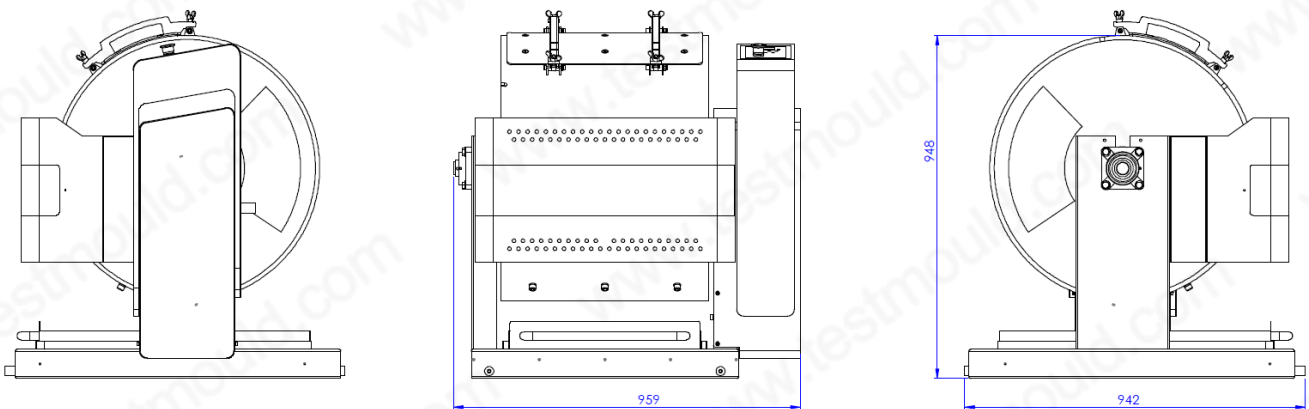

Notice

Note that the direction shown in the figure is the correct direction of rotation.

The red part is for lifting, a total of 4 at the front and rear.



C-TECH LABORATORY EQUIPMENT CO., LTD

📍 Building C28, Hegu Technology Industrial Park, Development Zone, Zhuozhou, Hebei, China

☎ +86-312-3868016/3852880

📠 +86-312-3868882

V. Operation

Machine

The Los Angeles Abrasion Testing Machine consists of a hollow steel drum, closed at both ends, having an inside diameter of 710mm and inside length of 510mm. The drum mounted on stub shafts attached the ends of the drum but not entering it and mounted in such a manner that it may be rotated about its axis in a horizontal position.

An opening in the drum is provided for the introduction of the test sample. The opening can be closed dust-tight with the removable cover bolted in place. The cover is so designed as to maintain the cylindrical contour of the interior surface. The shelf is so located that the charge will not fall in the cover or come in contact with it during the test.

A removable steel shelf projecting a radial 3- 1/2" into the drum and extending its full length is mounted along one element of the interior surface of the drum. The shelf is of such thickness and so mounted by bolts or other approved means to be firm & rigid. The position of the shelf is such that the distance from the shelf to the opening measured along the circumference of the drum in the direction of rotation is not less than 50".

If the cover stops at the bottom in a difficult to reach location, jog the barrel by pushing the outer weight-plate forward then reverse and pull to jog the barrel to the desired position.

Abrasive charges

The abrasive charges consist of cast-iron spheres or steel spheres approximately 1-7/8" in diameter and each weighing between 390g and 445g. The abrasive charge depending upon the grading of the test sample as described on page 4 shall be as follows:

Grading	Number of Spheres	Weight of Charges, g.
A	12	5000 ± 25
B	11	4584 ± 25
C	8	3330 ± 20
D	6	2500 ± 15



C-TECH LABORATORY EQUIPMENT CO., LTD

 Building C28, Hegu Technology Industrial Park, Development Zone, Zhuozhou, Hebei, China

 +86-312-3868016/3852880

 +86-312-3868882

Test Sample

The test sample shall consist of clean aggregate that has been dried in an oven at 105 °C to 110 °C (221 °F to 230 °F) substantially to constant weight and shall conform to a grading shown in Table 1. The grading used shall be the most nearly representing the aggregate furnished for the work.

Test procedure

Before test, firstly connect through three-phase 380V power, and check whether the input and working output aviation plug connected firmly. Check that the drum is clean before loading the sample. Carefully place the balls in the machine, then the test portion. Replace the cover and rotate the machine for 500 revolutions at a constant speed between 31 min⁻¹ and 33 min⁻¹.

- ①. Turn on the power switch. The upper screen is a counter that records the current compaction times, and the lower screen shows the preset compaction times. According to actual needs, press SET to preset the rotation times, and use + or - to adjust the value. Press RESET to reset the counter.
- ②. Press the jog button by hand to observe the rotation direction.

Note 1: the direction of rotation should be consistent with the previous figure, otherwise, change the phase sequence of the power cable, and you can arbitrarily exchange two of them.

Note 2: the counter does not count when you press JOG, and the counter will start counting after you press START.

- ③. After everything is normal, press the "Start" button and the equipment starts to work.
- ④. After the rotation finished, open the drum to pour the aggregate into a tray placed under the apparatus, taking care that the opening is just above the tray in order to avoid losing any material.



C-TECH LABORATORY EQUIPMENT CO., LTD

📍 Building C28, Hegu Technology Industrial Park, Development Zone, Zhuozhou, Hebei, China

☎ +86-312-3868016/3852880

📠 +86-312-3868882

Clean out the drum, removing all fines, paying particular attention around the projecting shelf.
Carefully remove the ball load from the tray, taking care not to lose any aggregate particles.

After test finished, clean the equipment and cut off the power.



C-TECH LABORATORY EQUIPMENT CO., LTD

 Building C28, Hegu Technology Industrial Park, Development Zone,
Zhuozhou, Hebei, China

 +86-312-3868016/3852880

 +86-312-3868882



Laboratory equipment co.,limited

CIVIL ENGINEERING TESTING EQUIPMENT MANUFACTURER