

DILATOMETER MARCHETTI TEST KIT

STANDARD: EN 1097-1, EN 13450, NF P18-576

The Dilatometer Marchetti Test (DMT) is an in-situ test for the determination of various key soil parameters used for geotechnical design, like lateral pressure coefficient K_0 , pore water pressure U , undrained shear strength C_u , effective angle of internal friction, coefficient of subgrade reaction K_n , over-consolidation ratio OCR, compression modulus, modulus of elasticity, shear modulus, layer classification, compaction control, unit weight, determination of liquefaction of saturated soil and so on. Generally the flat dilatometer can be pressed into earth by CPT machine, and can also by the hammer of SCPT machine.

The main part of the flat dilatometer consists of a flat stainless thin steel blade with a circular expandable steel membrane of 60 mm diameter on one side. The test involves driving this steel blade into the ground, inflate the steel membrane and measure the corresponding pressure and deformation. Penetration of the steel blade is usually done using common in-situ penetration equipment as for instance those used for Standard Penetration Test. The membrane of the blade is connected to a gas pressure unit on the surface which provide the pressure to inflate the steel membrane.



TECHNICAL SPECIFICATIONS

Flat blade	Length: 230-240mm Width: 95mm Thickness:15mm
Steel Membrane	60mm
Rated air pressure	6MPa
Test Depth	0-50m Special strata can be deepened
Indicating error	±0.1%F.S
Storage	Test result hole storage quantity can reach 9999
Power supply	Rechargeable Lithium batteries, standby time up to 24 hours

EQUIPMENT COMPOSITION

DMT-W3 Dilatometer Marchetti Test Kit complete set includes below items

DMT-W3/01	Control unit	DMT-W3/02	Control Recorder DMT-W3/
DMT-W3/03	Pressure regulation valve	DMT-W3/04	Air supply tube
DMT-W3/05	Solid probe head	DMT-W3/06	Flat blade
DMT-W3/07	Membrane	DMT-W3/08	Membrane gasket
DMT-W3/09	Standard pneumatic-electric cable	DMT-W3/10	Calibration cable
DMT-W3/11	Air pressure gauge	DMT-W3/12	Probe upper connector
DMT-W3/13	Calibration unit	DMT-W3/14	English operation manual
DMT-W3/15 Tool parts includes below items			
DMT-W3/1501	Monkey spanner 6 inch	DMT-W3/1502	0.5mm Thickness gauge
DMT-W3/1503	9—11 Hard wrench	DMT-W3/1504	150mm Ruler
DMT-W3/1505	10 inch Large spanner	DMT-W3/1506	Ring screw
DMT-W3/1507	4 inch Instrument driver	DMT-W3/1508	Wire-cutter
DMT-W3/1509	Stainless steel tweezers	DMT-W3/1510	Pulling tool
DMT-W3/1511	Brush	DMT-W3/1512	Sealing parts

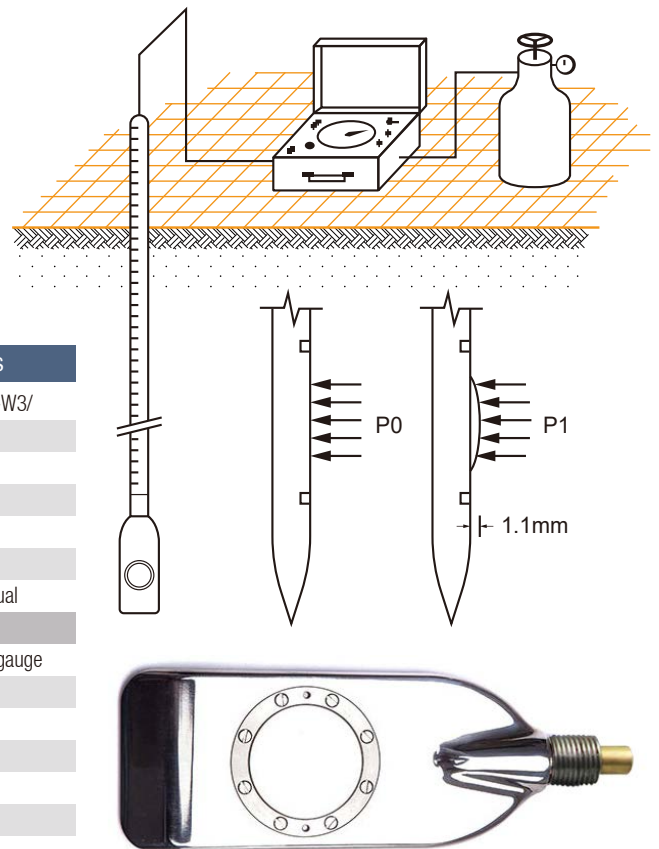

FLAT DILATOMETER TEST RESULTS TABLE

Project Name: Test															Date of Test: 2016-06-18		Prepared:		
Project No.: 1																	Checked:		
Hole No.: ZK1																	Reviewed:		
		Before test		After test				average value											
ΔA (kPa)		10		10		ΔA_{avg} (kPa)		10.0											
ΔB (kPa)		92		92		ΔB_{avg} (kPa)		92.0											
Groundwater depth(m): 0.5				unit weight of soil γ (kN/m ³): 18															
Zm: 0																			
No.	Depth d (m)	A (kPa)	B (kPa)	C (kPa)	p ₀ (kPa)	p ₁ (kPa)	p ₂ (kPa)	p ₁ -p ₀ (kPa)	Pore Water Pressure U ₀ (kPa)	Effective Vertical Stress σ'_{vo} (kPa)	Dilatometer Material Index I _D (-)	Horizontal Stress Index K _D (-)	Dilatometer Modulus E _D (MPa)	Coef. Earth Pressure at rest K ₀ (-)	Overconsolidation Ratio OCR (-)	Vertical drained Constrained Modulus M (MPa)	Undrained Shear Strength C _u (kPa)	Friction Angle ϕ (°)	Remarks
1	2.2	199	323		207.9	231.0		23.1	16.677	22.6	0.121	8.461	0.802	1.65	9.49	1.87	30.2		
2	2.4	185	315		193.6	223.0		29.4	18.639	24.2	0.168	7.230	1.020	1.49	7.42	2.21	26.5		
3	2.6	133	265		141.5	173.0		31.5	20.601	25.8	0.261	4.886	1.093	1.11	3.77	1.88	16.5		
4	2.8	137	288		144.6	196.0		51.5	22.563	27.4	0.422	4.452	1.785	1.07	3.48	2.98	16.4		
5	3	142	265	52	151.0	173.0	62.0	22.1	24.525	29.0	0.174	4.359	0.765	1.05	3.37	1.26	16.9		
6	3.2	144	251		153.8	159.0		5.2	26.487	30.6	0.041	4.159	0.182	1.01	3.13	0.29	16.8		
7	3.4	150	265		159.4	173.0		13.7	28.449	32.2	0.104	4.065	0.474	1.00	3.02	0.75	17.2		
8	3.6	152	265		161.5	173.0		11.6	30.411	33.8	0.088	3.877	0.401	0.96	2.81	0.61	17.0		
9	3.8	158	301		166.0	209.0		43.1	32.373	35.4	0.322	3.773	1.494	0.94	2.69	2.24	17.2		
10	4	164	299	63	172.4	207.0	73.0	34.7	34.335	37.0	0.251	3.730	1.202	0.93	2.64	1.79	17.7		
11	4.2	166	288		175.0	196.0		21.0	36.297	38.6	0.151	3.593	0.729	0.91	2.49	1.06	17.7		
12	4.4	197	378		203.1	286.0		83.0	38.259	40.2	0.503	4.099	2.878	1.00	3.06	4.57	21.7		
13	4.6	199	356		206.3	264.0		57.8	40.221	41.8	0.348	3.972	2.004	0.98	2.92	3.11	21.7		
14	4.8	183	316		191.5	224.0		32.6	42.183	43.4	0.218	3.439	1.129	0.88	2.33	1.59	18.8		
15	5	167	299	57	175.5	207.0	67.0	31.5	44.145	45.0	0.240	2.919	1.093	0.77	1.80	1.35	15.9		
16	5.2	188	324		196.3	232.0		35.7	46.107	46.6	0.238	3.223	1.239	0.83	2.11	1.66	18.6		
17	5.4	190	306		199.3	214.0		14.7	48.069	48.2	0.097	3.138	0.510	0.81	2.02	0.67	18.6		
18	5.6	180	305		188.9	213.0		24.2	50.031	49.8	0.174	2.788	0.838	0.74	1.68	1.00	16.6		
19	5.8	190	314		198.9	222.0		23.1	51.993	51.4	0.157	2.858	0.802	0.75	1.75	0.97	17.7		
20	6	184	300	94	193.3	208.0	104.0	14.7	53.955	53.0	0.105	2.629	0.510	0.70	1.53	0.58	16.4		
21	6.2	182	307		190.9	215.0		24.2	55.917	54.6	0.179	2.471	0.838	0.66	1.39	0.89	15.6		
22	6.4	189	305		198.3	213.0		14.7	57.879	56.2	0.105	2.499	0.510	0.67	1.42	0.55	16.3		
23	6.6	199	322		208.0	230.0		22.1	59.841	57.8	0.149	2.562	0.765	0.69	1.47	0.85	17.3		
24	6.8	204	331		212.8	239.0		26.3	61.803	59.4	0.174	2.541	0.911	0.68	1.45	1.00	17.6		
25	7	209	333	101	217.9	241.0	111.0	23.1	63.765	61.0	0.150	2.527	0.802	0.68	1.44	0.87	18.0		
26	7.2	209	338		217.7	246.0		28.4	65.727	62.6	0.197	2.427	0.984	0.65	1.35	1.03	17.5		
27	7.4	212	332		221.1	240.0		18.9	67.689	64.2	0.123	2.390	0.656	0.64	1.32	0.68	17.6		
28	7.6	216	342		224.8	250.0		25.2	69.651	65.8	0.162	2.358	0.874	0.64	1.29	0.89	17.8		